

Exterior Compensators

DESCRIPTION OF THE PRODUCT:

Exterior compensators / flexible joints are very durable fabric air ducts suitable for the outdoor environment. They are used to connect HVAC systems ducts on the roof of the vehicle, compensate the tolerances and shifts of neighboring components and eliminate noise transfer. They can contain one or more chambers and are connected with sealed aluminum or stainless-steel flanges.



COMPOSITION:

(The geometry is customizable.)

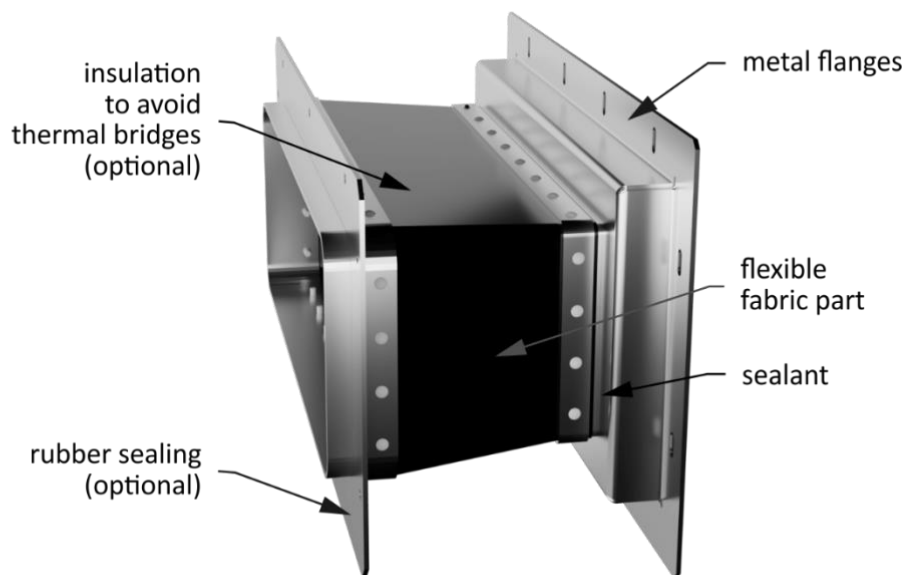

PROPERTIES:

- | | |
|--------------|---|
| Very durable | Fire resistant |
| UV resistant | Ozone resistant |
| Waterproof | Temperature resistant (-50 °C to +100 °C) |

SCREW CONNECTION:

Widely recognized and familiar technology
Durable and long-lasting option

FIRE PROTECTION CLASSES:

- EN 45545-2 R1 HL2
- EN 45545-2 R1 HL3
- NFPA 130